



VORTICENT CMS RANGE

MEDIUM-PRESSURE INDUSTRIAL CENTRIFUGAL FANS





VORTICE S.p.A. is part of a multinational group,^[1] **VORTICE GROUP**, which operates through its own companies or local distributors in over 90 countries worldwide and has a rich product portfolio that guarantees air quality and climate comfort. The headquarters of VORTICE S.p.A are in Tribiano (Milan).



VORTICE GROUP also includes:

^[1/2] **BUSINESS UNIT INDUSTRIAL**, born from the acquisition in 2010 of Loran srl, based in Isola della Scala (VR). 2024 become Vortice's BUSINESS UNIT INDUSTRIAL.

^[3] **VORTICE LIMITED**, the UK subsidiary of VORTICE S.p.A., established in 1977 and based in Burton on Trent.

^[4] **VORTICE VENTILATION SYSTEM**, a company inaugurated in 2013 with headquarters in Changzhou, China.

^[5] **CASALS VENTILACIÓN AIR INDUSTRIAL S.L.**, historic Spanish brand, based in Sant Joan de les Abadesses, Girona, acquired in 2019.

^[6] **VORTICE LATAM S.A.**, based in Alajuela in Costa Rica, established in 2012.

^[7] **VORTICE POLSKA** new representative office in Warsaw, Poland, established in 2026.

VORTICENT CMS RANGE

Medium-pressure industrial centrifugal fans

Medium-pressure industrial centrifugal fans with forward-curved impellers, particularly suitable for industrial applications, such as the cooling of machinery or components, etc.



Regulatory Standards

The products in the CMS series comply with the following European standards, directives and regulations

- **Safety requirements relating to the Machinery Directive:**
 - EN ISO 12100
 - EN 60204-1
 - EN 13857
 - EN12499
- **European Directives and Regulations for CE Marking:**
 - Machinery Directive (2006/42/CE)
 - Electromagnetic Compatibility Directive (2014/30/UE)
 - ERP Directive 2009/125/CE (regulations 327/2011/UE)
- **Electromagnetic Compatibility Standards:**
 - EN 55014-1
 - EN 55014-2
 - EN 61000-3-2
 - EN 61000-3-3

VORTICENT CMS RANGE

Medium-pressure industrial centrifugal fans with forward-curved impellers, particularly suitable for industrial applications, for cooling machinery or components, and for conveying clean air.

- **Product range:**
- **7 single-phase models, 32 three-phase models.**
13 sizes: 12/5, 14/5, 16/6, 18/7, 20/6, 20/8, 22/9, 25/10, 28/11, 31/12, 35/14, 40/16, 45/18.
- **Construction:**
- Enclosures made of sheet steel, joined by bolts or welded together, with an epoxy powder coating.
- 2-, 4- and 6-pole AC motors, single-phase or three-phase, Class F, with IP 55 protection. Single-phase power supply at 230V-50Hz, three-phase at 230/400V-50Hz for motors up to 5.5kW, or three-phase at 400/690V-50Hz for motors of higher power.
- Forward-curved centrifugal impellers, single-suction, made from galvanised sheet steel.
- Maximum continuous operating temperature: conveyed air +130°C; ambient air +50°C (single-phase motors), +60°C (three-phase motors).
- Default orientation: LG 270.

KEY FEATURES

- High overall efficiency, thanks to the use of forward-curved centrifugal impellers, which combine high performance with proportionally low energy consumption.
- High performance.
- High temperatures of the treated air.
- Special versions are available on request with:
 - Alternative voltages,
 - 2-speed motors,
 - Fans for conveying air up to +250°C (depending on the model),
 - Cooling fan,
 - Different approaches: LG 0, LG 45, LG 90, LG 135, LG 180, LG 225, LG 315, RD 0, RD 45, RD 90, RD 135, RD 180, RD 225, RD 270, RD 315.



TECHNICAL DATA

MODELS	CODE	Motor Class	V~ 50 Hz	(W)	Current consumption (A) 230 V	Current consumption (A) 400 V	(A) Max	Maximum flow rate m ³ /h	RPM	IP	Kg	Operating temperature °C
CMS 14/5 M2 0,25 kW	30134	F	230	250	-	-	1,77	800	2790	55	9,5	50
CMS 16/6 M2 0,37 kW	30135	F	230	370	-	-	2,47	1050	2858	55	7	50
CMS 18/7 M2 0,75 kW	30136	F	230	750	-	-	4,49	1540	2810	55	15	50
CMS 20/8 M2 1,1 kW	30138	F	230	1100	-	-	6,71	2000	2800	55	19	50
CMS 12/5 M4 0,06 kW	30139	F	230	60	-	-	0,58	250	1400	55	5	50
CMS 14/5 M4 0,06 kW	30140	F	230	60	-	-	0,58	415	1400	55	6	50
CMS 16/6 M4 0,12 kW	30141	F	230	120	-	-	0,93	680	1380	55	7,5	50
CMS 14/5 T2 0,25 kW	30142	F	230	250	1,12	0,65	250	800	2800	55	7	60
CMS 16/6 T2 0,37 kW	30143	F	230/400	370	1,58	0,91	-	1050	2800	55	9,5	60
CMS 18/7 T2 0,75 kW	30144	F	230/400	750	2,75	1,58	750	1540	2800	55	15	60
CMS 20/8 T2 1,1 kW	30146	F	230/400	1100	4,05	2,33	-	2000	2800	55	19	60
CMS 12/5 T4 0,06 kW	30147	F	230/400	60	0,47	0,27	-	250	1400	55	5	60
CMS 14/5 T4 0,06 kW	30148	F	230/400	60	0,47	0,27	-	415	1400	55	6	60
CMS 16/6 T4 0,12 kW	30149	F	230/400	120	0,8	0,46	-	710	1400	55	7,5	60
CMS 22/9 T2 1,1 kW	30150	F	230/400	1100	4,05	2,33	-	1480	2800	55	24	60
CMS 22/9 T2 2,2 kW	30151	F	230/400	2200	7,97	4,58	-	2890	2840	55	30	60
CMS 25/10 T2 2,2 kW	30152	F	230/400	2200	7,97	4,58	-	2540	2840	55	32	60
CMS 25/10 T2 3 kW	30153	F	230/400	3000	10,3	5,92	-	3360	2880	55	38	60
CMS 28/11 T2 4 kW	30154	F	230/400	4000	13,3	7,63	-	3600	2880	55	46	60
CMS 22/9 T4 0,37 kW	30155	F	230/400	370	1,86	1,07	-	1810	1370	55	21	60
CMS 25/10 T4 0,75 kW	30156	F	230/400	750	2,83	1,63	-	2830	1410	55	26	60
CMS 28/11 T4 1 kW	30157	F	230/400	1100	4,33	2,49	-	3580	1450	55	32	60
CMS 31/2 T4 2,2 kW	30158	F	230/400	2200	8,07	4,64	-	5400	1435	55	54	60
CMS 35/14 T4 3 kW	30159	F	230/400	3000	10,7	6,7	-	5870	1420	55	63	60
CMS 35/14 T4 4 kW	30160	F	230/400	4000	14,5	8,32	-	8020	1440	55	69	60
CMS 35/14 T6 1,1 kW	30165	F	230/400	1100	4,83	2,78	-	5200	925	55	53	60
CMS 40/16 T6 1,5 kW	30166	F	230/400	1500	6,45	3,71	-	5650	940	55	94	60
CMS 40/16 T6 2,2 kW	30167	F	230/400	2200	10,3	5,94	-	8100	965	55	94	60
CMS 45/18 T6 2,2 kW	30168	F	230/400	2200	10,3	5,94	-	6060	965	55	112	60
CMS 22/9 T2 1,5 kW	30185	F	230/400	1500	5,83	3,14	-	2030	2865	55	24	60
CMS 31/12 T2 3 kW P/R	30186	F	230/400		10,3	5,92	-	5310	2880	55	55	60

MODELS	CODE	Motor Class	V~ 50 Hz	(W)	Current consumption (A) 400 V	Current consumption (A) 690 V	Maximum flow rate m ³ /h	RPM	IP	Kg	Operating temperature °C
CMS 40/16 T4 5,5 kW	30161	F	400/690	5500	10,5	6,09	8340	1460	55	101	60
CMS 40/16 T4 7,5 kW	30162	F	400/690	7500	14,1	8,17	10570	1455	55	110	60
CMS 45/18 T4 7,5 kW	30163	F	400/690	7500	14,1	8,17	9160	1455	55	119	60
CMS 45/18 T4 1 kW	30164	F	400/690	1100	21,2	12,3	12500	1455	55	190	60
CMS 35/14 T2 5,5 kW P/R	30187	F	400/690	5500	10,6	6,14	7810	2910	55	85	60
CMS 40/16 T2 7,5 kW P/R	30188	F	400/690	7500	14,1	8,17	9510	2910	55	103	60
CMS 45/18 T2 11 kW P/R	30189	F	400/690	11000	20,8	12,1	10510	2940	55	180	60
CMS 45/18 T2 15 kW P/R	30190	F	400/690	15000	27,4	15,9	12510	2935	55	191	60

VORTICENT CMS
Medium-pressure industrial centrifugal fans

DIMENSIONS

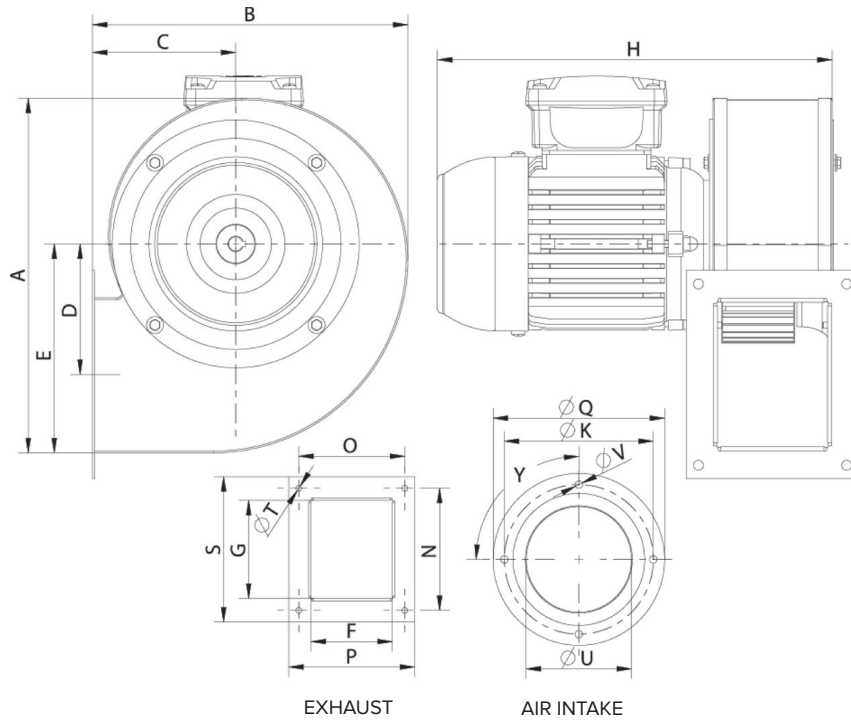

MODELS	CODE	A	B	C	D	E	F	G	H	K	N	O	P	Q	S	ØT	ØU	ØV	Y
CMS 14/5 M2 0,25 kW	30134	250,5	224	102	93	147,5	82	106	278	162	128	105	123	175	147	7	115	7	4X90°
CMS 16/6 M2 0,37 kW	30135	295	266	119	108	171,5	100	120	325	180	147	128	152	207	172	7	127	9	4X90°
CMS 18/7 M2 0,75 kW	30136	350	305	130	133	205	115	140	358	214	169	146	169	237	192	8	143	9	4X90°
CMS 20/8 M2 1,1 kW	30138	374	320	138	139	221	130	160	372	230	189	160	184	255	213	8	161	9	8X45°
CMS 12/5 M4 0,06 kW	30139	205,5	188	87	71,5	117	72	85	251	135	105	93	106	150	118	7	92,5	7	4X90°
CMS 14/5 M4 0,06 kW	30140	250,5	224	102	93	147,5	82	106	278	162	128	105	123	175	147	7	115	7	4X90°
CMS 16/6 M4 0,12 kW	30141	295	266	119	108	171,5	100	120	325	180	147	128	152	207	172	7	127	9	4X90°
CMS 14/5 T2 0,25 kW	30142	250,5	224	102	93	147,5	82	106	278	162	128	105	123	175	147	7	115	7	4X90°
CMS 16/6 T2 0,37 kW	30143	295	266	119	108	171,5	100	120	325	180	147	128	152	207	172	7	127	9	4X90°
CMS 18/7 T2 0,75 kW	30144	350	305	130	133	205	115	140	358	214	169	146	169	237	192	8	143	9	4X90°
CMS 20/6 T2 0,37 kW	30145	347	302	132	150	202	105	100	329	230	128	134	159	255	153	8	161	9	8X45°
CMS 20/8 T2 1,1 kW	30146	374	320	138	139	221	130	160	372	230	189	160	184	255	213	8	161	9	8X45°
CMS 12/5 T4 0,06 kW	30147	205,5	188	87	71,5	117	72	85	251	135	105	93	106	150	118	7	92,5	7	4X90°
CMS 14/5 T4 0,06 kW	30148	250,5	224	102	93	147,5	82	106	278	162	128	105	123	175	147	7	115	7	4X90°
CMS 16/6 T4 0,12 kW	30149	295	266	119	108	171,5	100	120	325	180	147	128	152	207	172	7	127	9	4X90°

DIMENSIONS

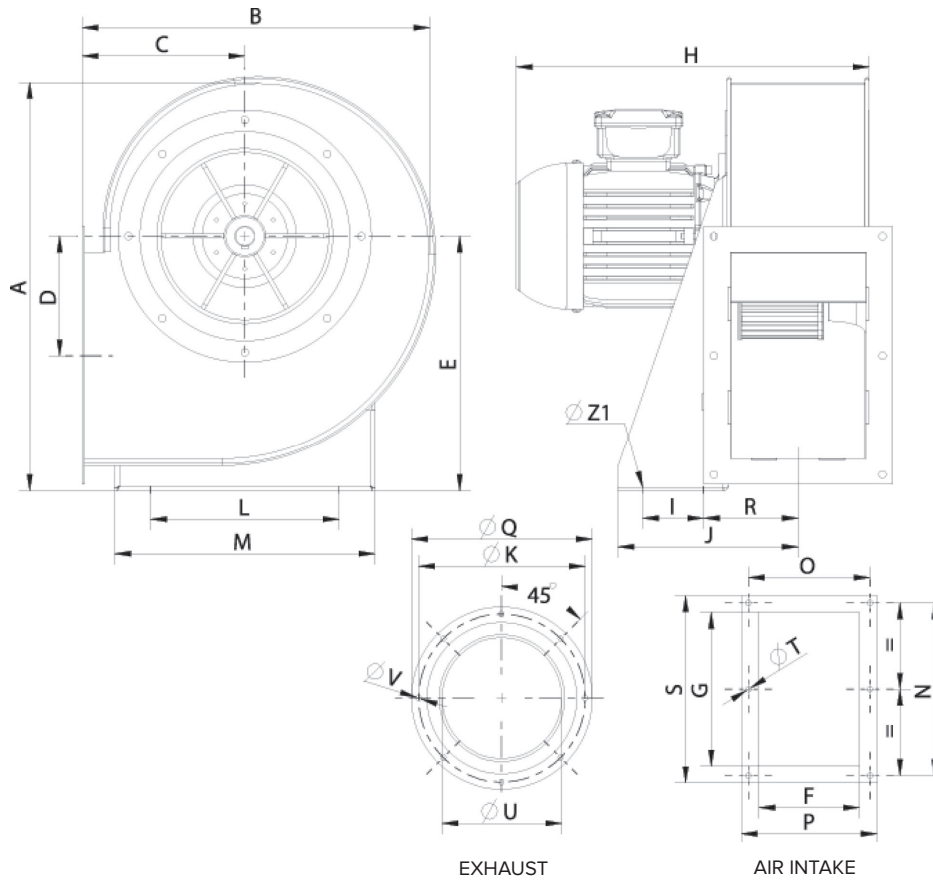

MODELS	CODE	A	B	C	D	E	F	G	H	I	J	K	L	M	N	O	P	Q	R	S	ØT	ØU	ØV	ØZ1
CMS 22/9 T2 1,1 kW	30150	447	382	181	134	280	140	216	403	50	182,5	256	220	290	256	180	204	280	102	282	9	180	9	11
CMS 22/9 T2 2,2 kW	30151	447	382	181	134	280	140	216	403	50	182,5	256	220	290	256	180	204	280	102	282	9	180	9	11
CMS 25/10 T2 2,2 kW	30152	496	420	197	142	310	165	254	463	74	202	282	228	315	290	205	229	306	114,5	314	9	203	9	13
CMS 25/10 T2 3 kW	30153	496	420	197	142	310	165	254	498	74	202	282	228	315	290	205	229	306	114,5	314	9	203	9	13
CMS 28/11 T2 4 kW	30154	549	468	216	154	340	180	300	529,5	95	234,5	320	245	350	340	220	244	348	110	364	9	228	9	13
CMS 22/9 T4 0,37 kW	30155	447	382	181	134	280	140	216	403	50	182,5	256	220	290	256	180	204	280	102	282	9	180	9	11
CMS 25/10 T4 0,75 kW	30156	496	420	197	142	310	165	254	427	74	202	282	228	315	290	205	229	306	114,5	314	9	203	9	13
CMS 28/11 T4 1 kW	30157	549	468	216	154	340	180	300	453,5	95	234,5	320	245	350	340	220	244	348	110	364	9	228	9	13
CMS 22/9 T2 1,5 kW	30185	455	393,5	184	140	280	140	216	385,5	50	182,5	256	220	290	256	180	204	280	102	282	9	180	9	11

VORTICENT CMS
Medium-pressure industrial centrifugal fans

DIMENSIONS

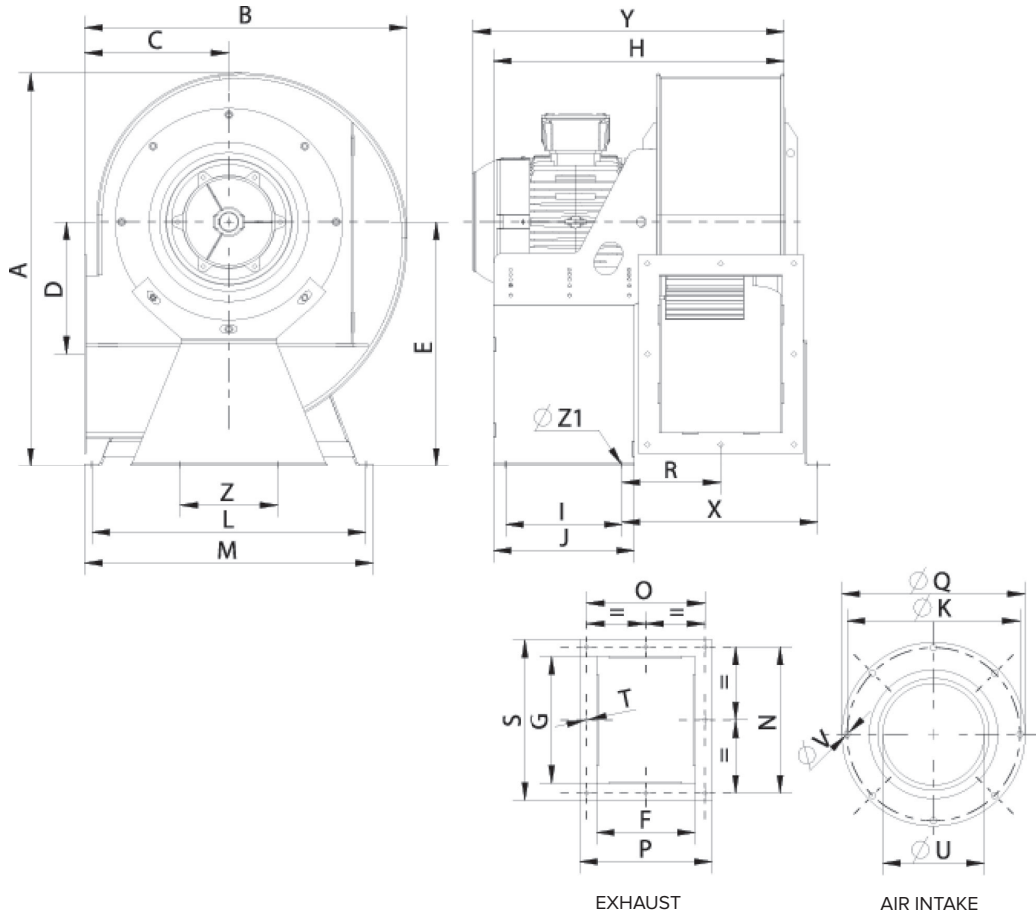

MODELS	CODE	A	B	C	D	E	F	G	H	I	J	K	L	M	N	O	P	Q	R	S	ØT	ØU	ØV	X	Y	Z	ØZ1
CMS 31/2 T4 2,2 kW	30158	640	531	249	180	406	198	319	538	240	290	354,5	457	482	360	240	274	382	171	395	11	203	11	*	539,5	*	13
CMS 35/14 T4 3 kW	30159	715	587	270	242	451	224	280	564	240	290	394,5	449	474	318	266	300	422	184	356	11	228	11	*	565,7	*	13
CMS 35/14 T4 4 kW	30160	715	587	270	242	451	224	280	564	240	290	394,5	449	474	318	266	300	422	184	356	11	288	11	*	565,7	*	13
CMS 40/16 T4 5,5 kW	30161	796	652	295	271	499	250	320	595	240	290	438	560	590	370	300	336	464	202	406	11	257	11	400	667,75	200	13
CMS 40/16 T4 7,5 kW	30162	796	652	295	271	499	250	320	595	240	290	438	560	590	370	300	336	464	202	406	11	257	11	400	707,75	200	13
CMS 45/18 T4 7,5 kW	30163	887	730	329	305	553	280	360	791	250	300	485	602	632	404	328	356	515	207	436	11	289	11	415	726,75	200	13
CMS 45/18 T4 1 kW	30164	887	730	329	305	553	280	360	791	400	300	485	602	632	404	328	356	515	207	436	11	289	11	438	802,75	200	13
CMS 35/14 T6 1,1 kW	30165	715	587	270	242	451	224	280	564	240	290	394,5	449	474	318	266	300	422	184	356	11	228	11	*	540	*	13
CMS 40/16 T6 1,5 kW	30166	796	652	295	271	499	250	320	595	240	290	438	560	590	370	300	336	464	202	406	11	257	11	400	612,75	200	13
CMS 40/16 T6 2,2 kW	30167	796	652	295	271	499	250	320	595	240	290	438	560	590	370	300	336	464	202	406	11	257	11	400	612,75	200	13
CMS 45/18 T6 2,2 kW	30168	887	730	329	305	553	280	360	791	250	300	485	602	632	404	328	356	515	207	436	11	289	11	415	631,75	200	13

* product without a base



DIMENSIONS

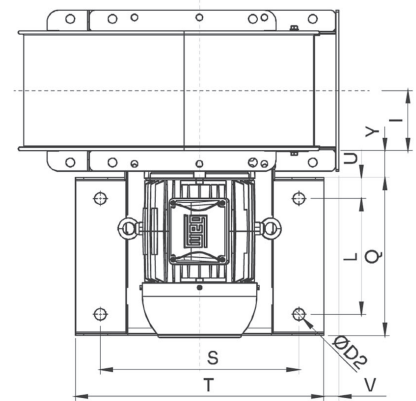
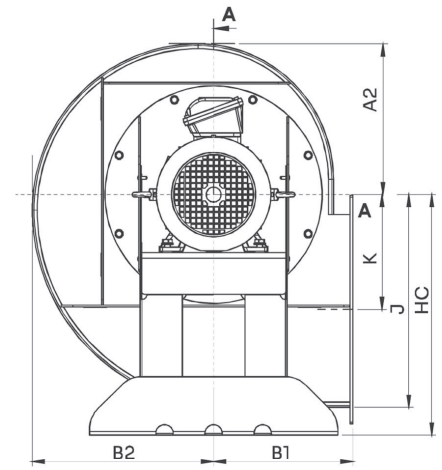
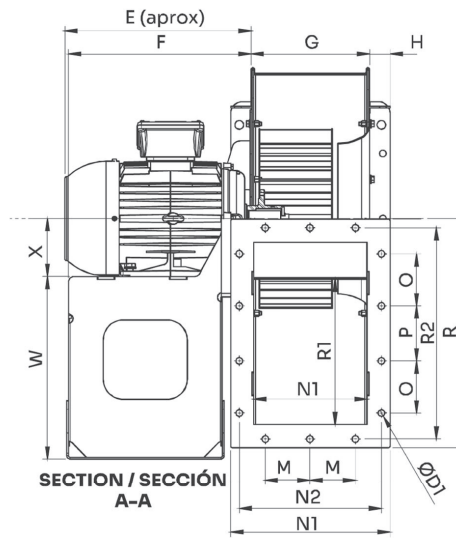
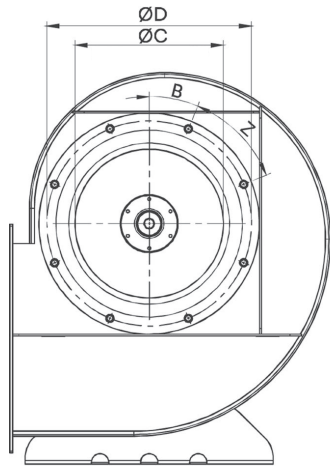

MODELS	CODE	A2	B	B1	B2	ØC	ØD	ØD1	ØD2	E	F	G	H	HC	I	J	K	L	M	N	N1
CMS 31/12 T2 3 kW P/R	30186	260,7	22,5	241,3	314,1	257,12	354,5	11,5	20	364,6	316,51	207	35,5	415,6	103,5	367,5	198,5	200	79	278	198
CMS 35/14 T2 5,5 kW P/R	30187	292,4	22,5	266,2	352,6	289	394,5	11,5	20	383,5	406,52	233	35,5	460,6	116,5	412,8	224,3	270	92	304	224
CMS 40/16 T2 7,5 kW P/R	30188	328,2	22,5	294,3	396,1	325	438	11,5	20	380,5	406,5	261	38,5	510,6	130,5	464	253	270	106	332	252
CMS 45/18 T2 11 kW P/R	30189	367,7	22,5	325,4	444	365	485	11,5	20	539,15	526,6	293	48,5	570,6	146,5	520,3	284,3	385	112	364	284
CMS 45/18 T2 15 kW P/R	30190	367,7	22,5	325,4	444	365	485	11,5	20	539,15	526,6	293	48,5	570,6	146,5	520,3	284,3	385	112	364	284

MODELS	CODE	N2	O	P	Q	R	R1	R2	S	T	U	V	W	X	Y	Z
CMS 31/12 T2 3 kW P/R	30186	248	90	95	272,95	395	251	365	344	430	36,47	26,3	315,6	100	46,47	8X45°
CMS 35/14 T2 5,5 kW P/R	30187	274	105	105	364,72	435	282	405	416	492	47,36	20,2	329,6	132	45,71	8X45°
CMS 40/16 T2 7,5 kW P/R	30188	302	120	120	364,7	480	322	450	397	473	47,36	57,8	378,6	132	45,71	8X45°
CMS 45/18 T2 11 kW P/R	30189	334	130	130	464,7	530	362	500	487	563	39,86	43,9	410,6	160	65,9	8X45°
CMS 45/18 T2 15 kW P/R	30190	334	130	130	464,7	530	362	500	487	563	39,86	43,9	410,6	160	65,9	8X45°

VORTICENT CMS
Medium-pressure industrial centrifugal fans

PERFORMANCE

CMS 14/5 M2 0,25 kW
Code 30134

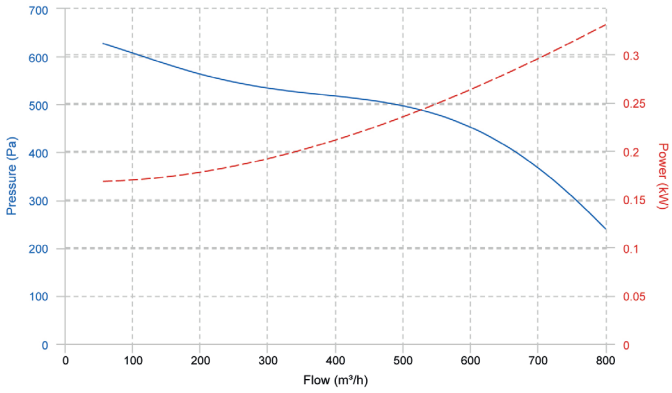

CMS 16/6 M2 0,37 kW
Code 30135

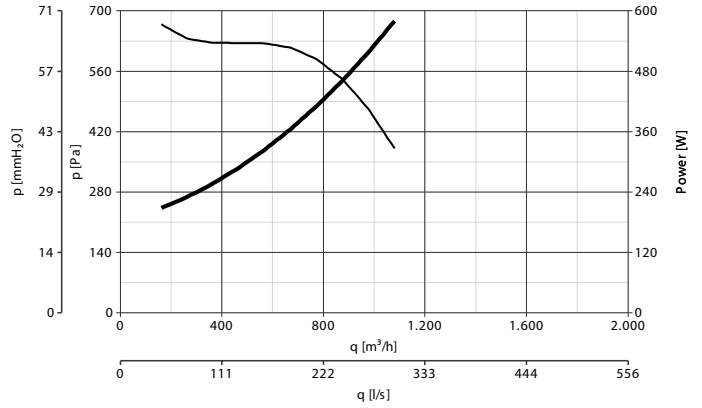

CMS 18/7 M2 0,75 kW
Code 30136

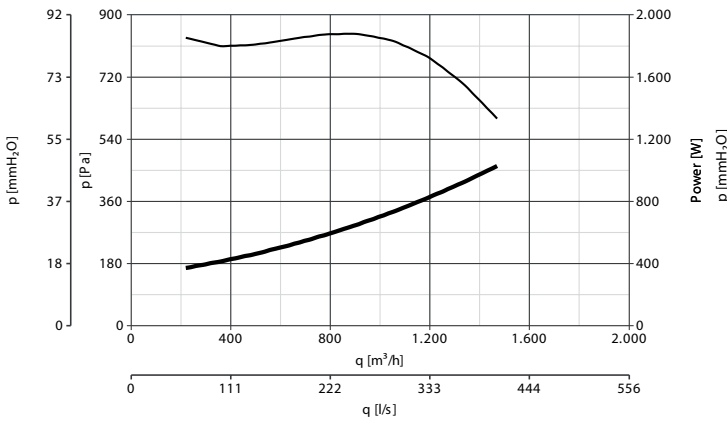

CMS 20/8 M2 1,1 kW
Code 30138

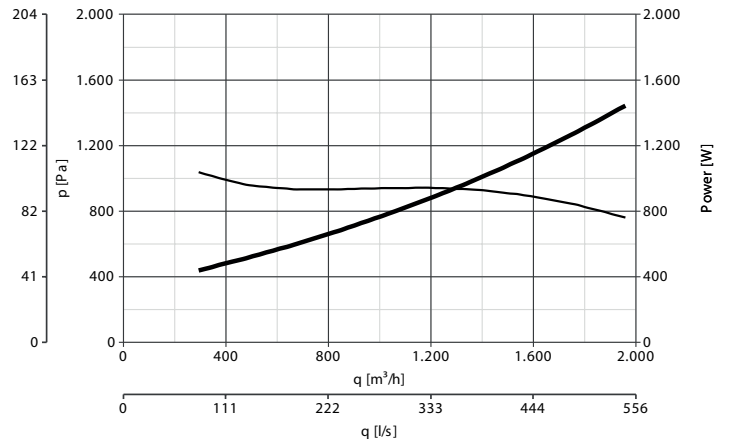

CMS 12/5 M4 0,06 kW
Code 30139

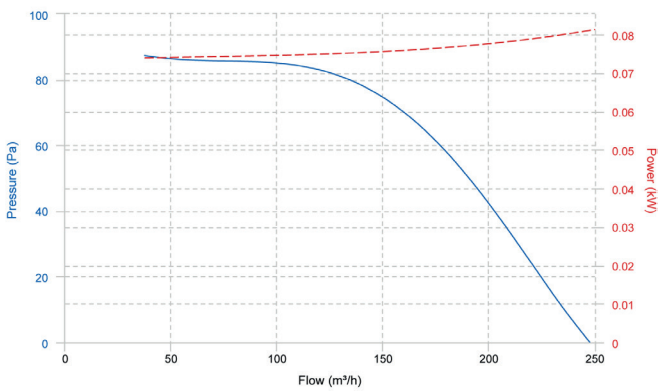

CMS 14/5 M4 0,06 kW
Code 30140

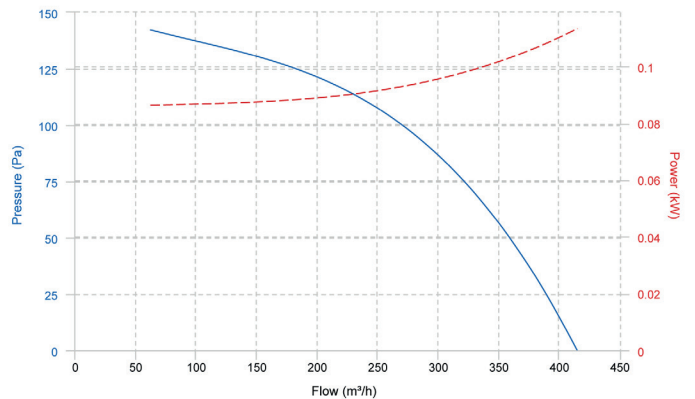



PERFORMANCE

CMS 16/6 M4 0,12 kW
Code 30141

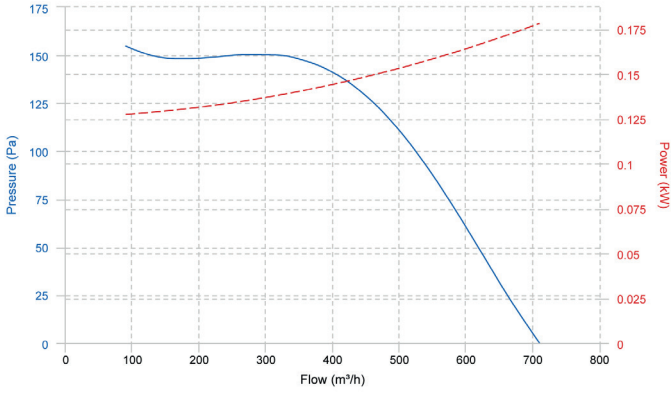

CMS 14/5 T2 0,25 kW
Code 30142

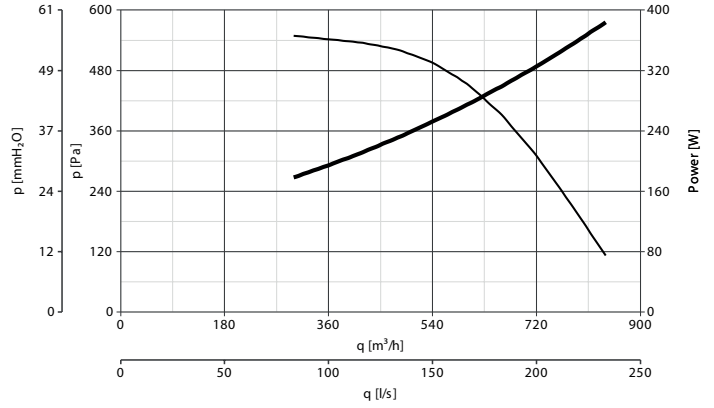

CMS 16/6 T2 0,37 kW
Code 30143

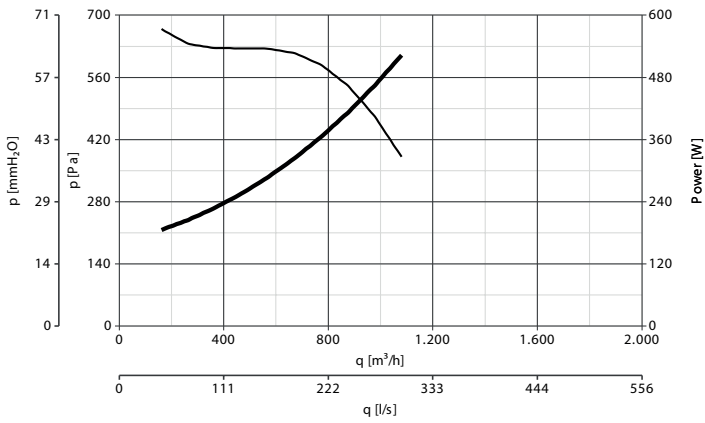

CMS 18/7 T2 0,75 kW
Code 30144

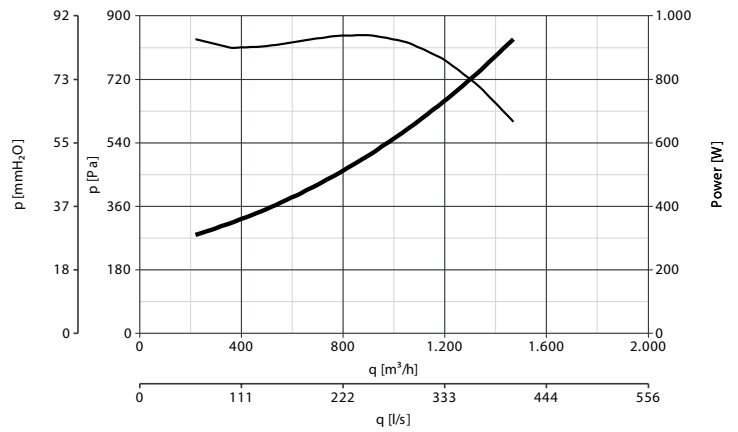

CMS 20/8 T2 1,1 kW
Code 30146

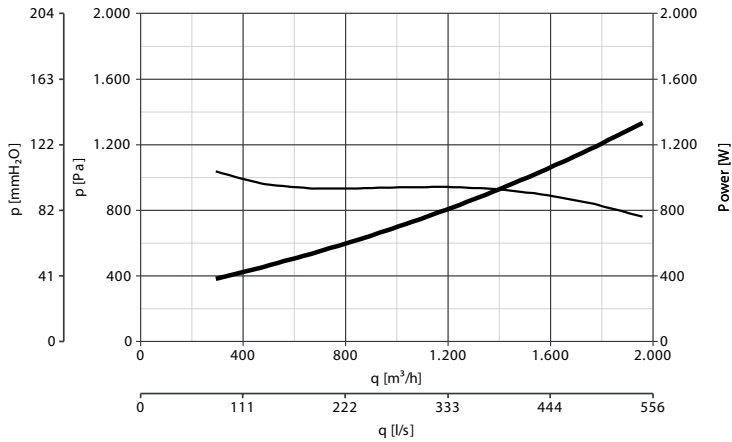

CMS 12/5 T4 0,06 kW
Code 30147

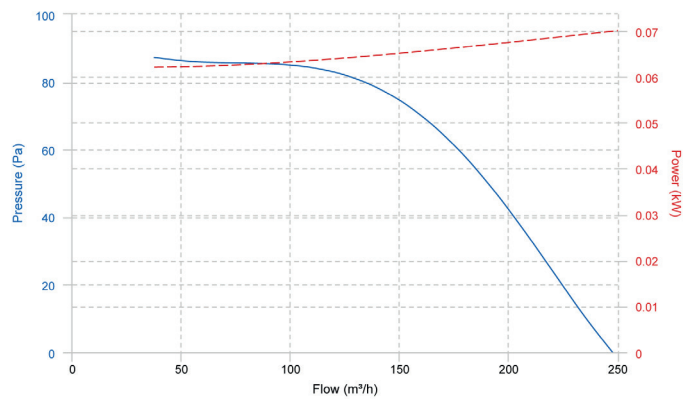

VORTICENT CMS
Medium-pressure industrial centrifugal fans

PERFORMANCE

CMS 14/5 T4 0,06 kW
Code 30148

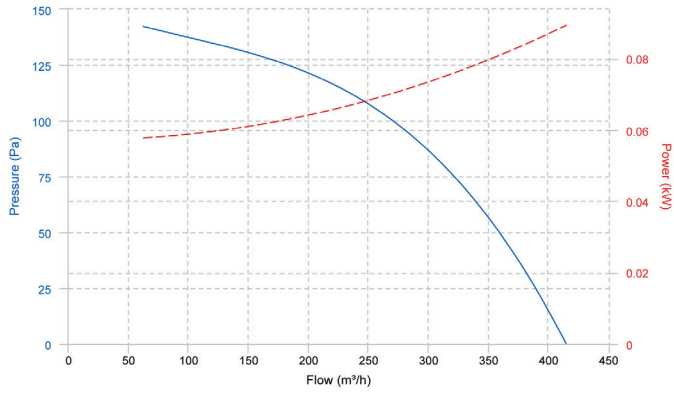

CMS 16/6T4 0,12 kW
Code 30149

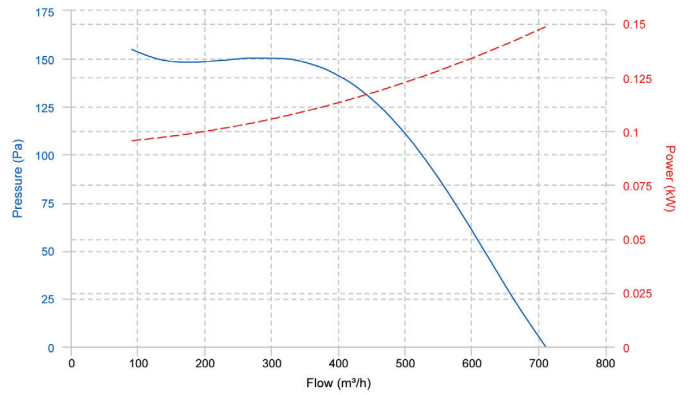

CMS 22/9 T2 1,1 kW
Code 30150

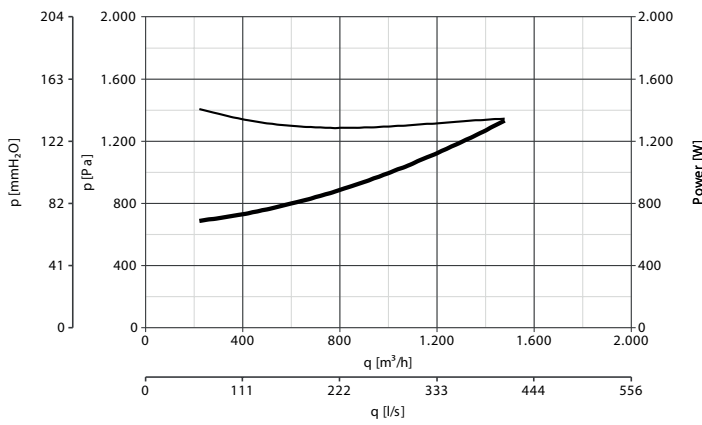

CMS 22/9 T2 2,2 kW
Code 30151

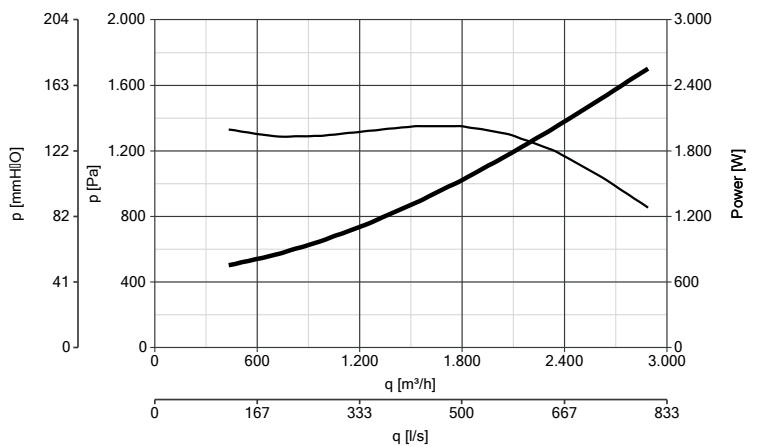

CMS 25/10 T2 2,2 kW
Code 30152

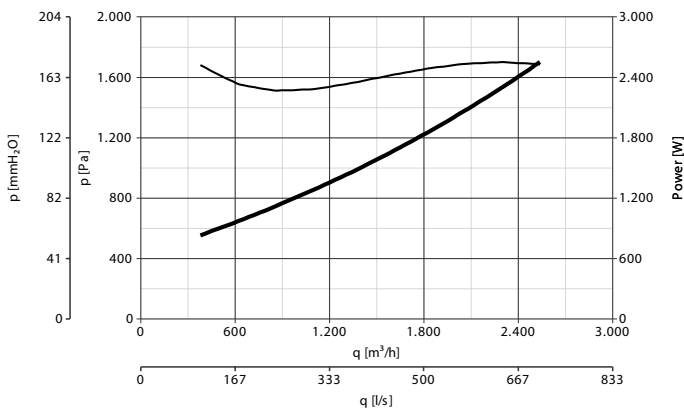

CMS 25/10 T2 3 kW
Code 30153

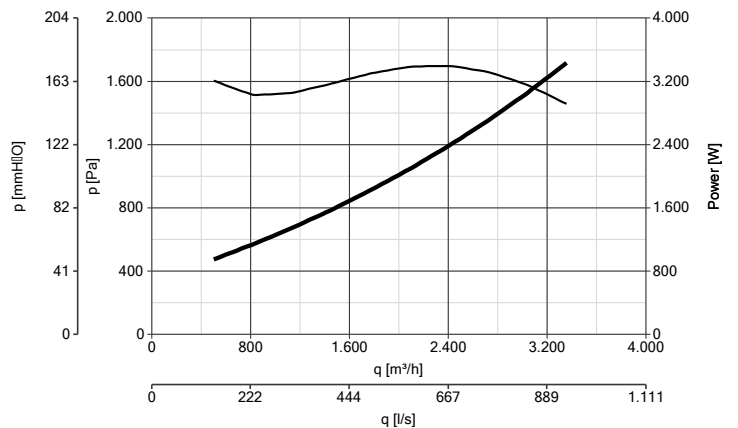



PERFORMANCE

CMS 28/11 T2 4 kW
Code 30154

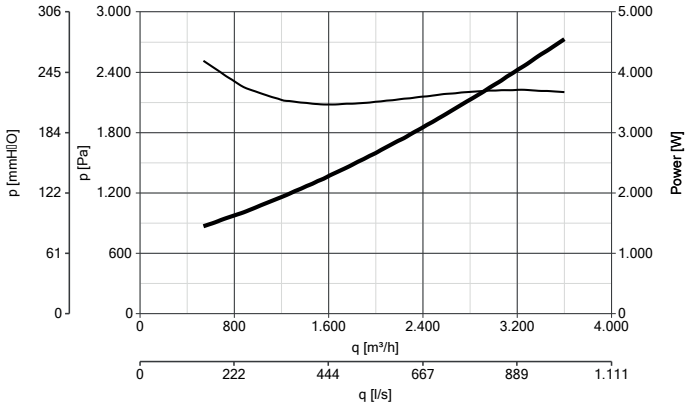

CMS 22/9 T4 0,37 kW
Code 30155

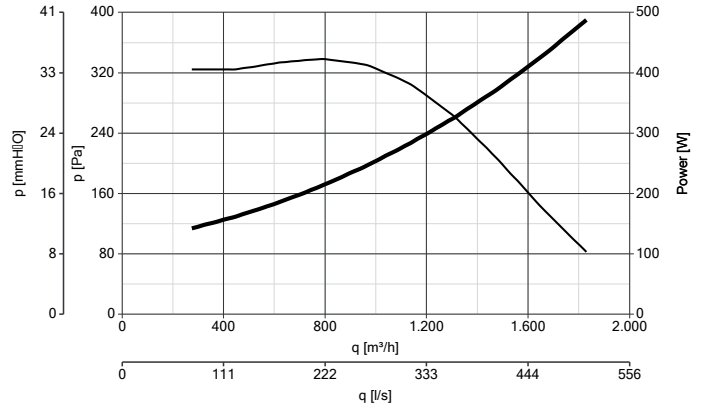

CMS 25/10 T4 0,75 kW
Code 30156

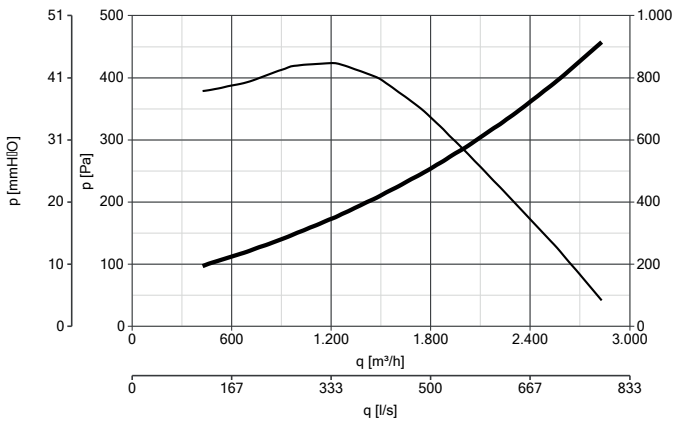

CMS 28/11 T4 1,1 kW
Code 30157

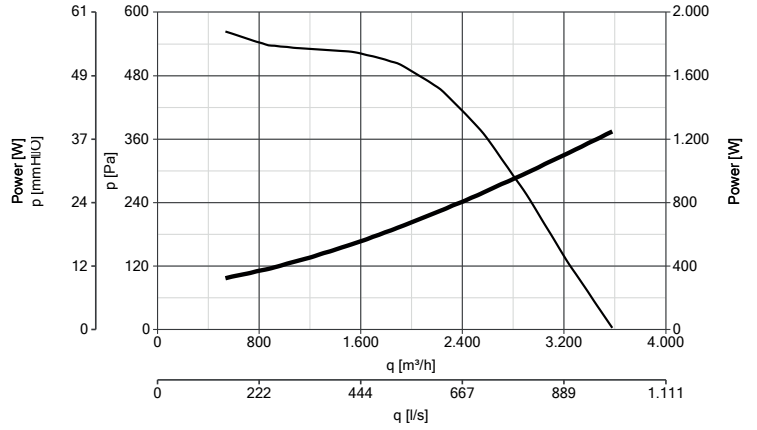

CMS 32/125 T4 2,2 kW
Code 30158

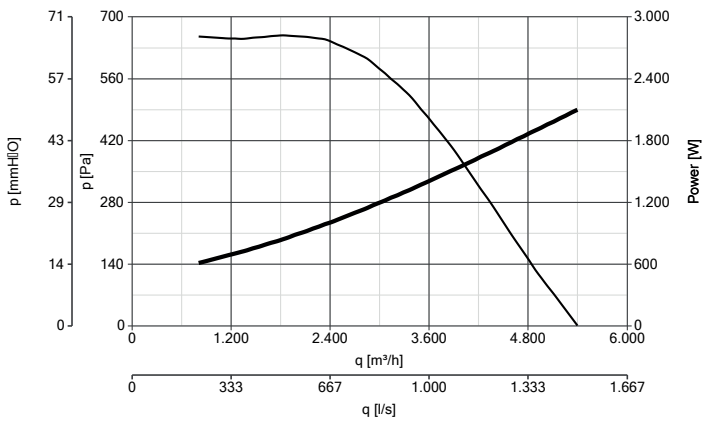

CMS 35/14 T4 3 kW
Code 30159

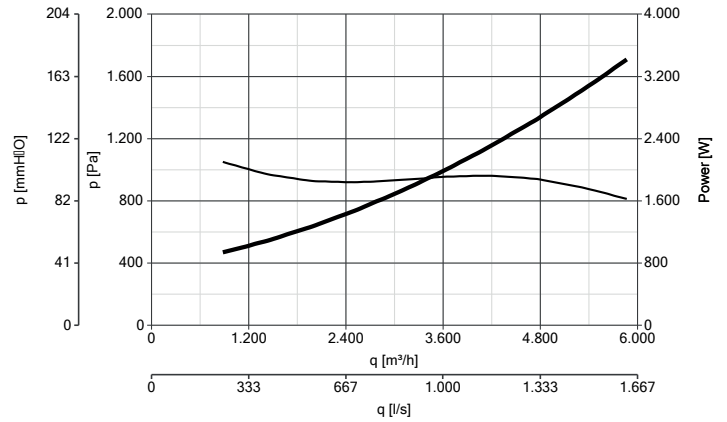

VORTICENT CMS
Medium-pressure industrial centrifugal fans

PERFORMANCE

CMS 35/14 T4 4 kW
Code 30160

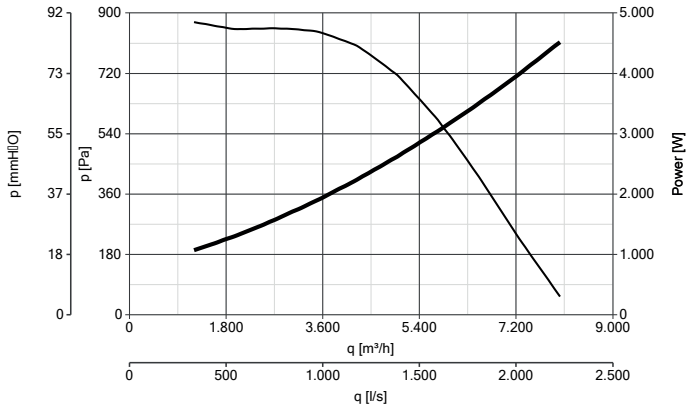

CMS 40/16 T4 5,5 kW
Code 30161

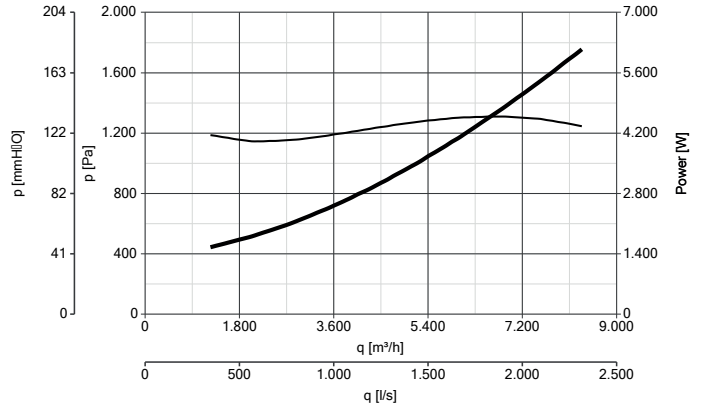

CMS 40/16 T4 7,5 kW
Code 30162

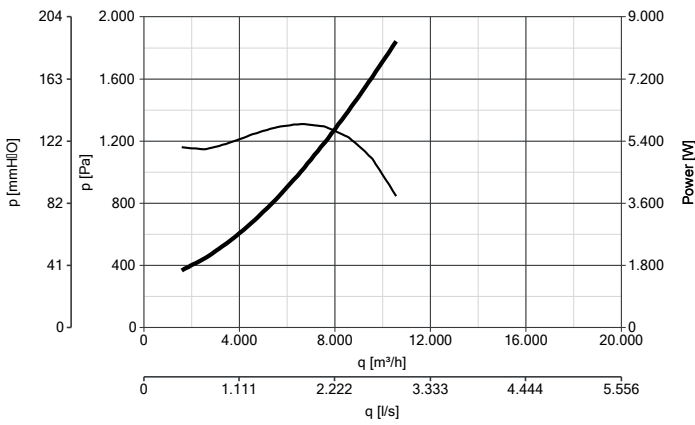

CMS 45/18 T4 7,5 kW
Code 30163

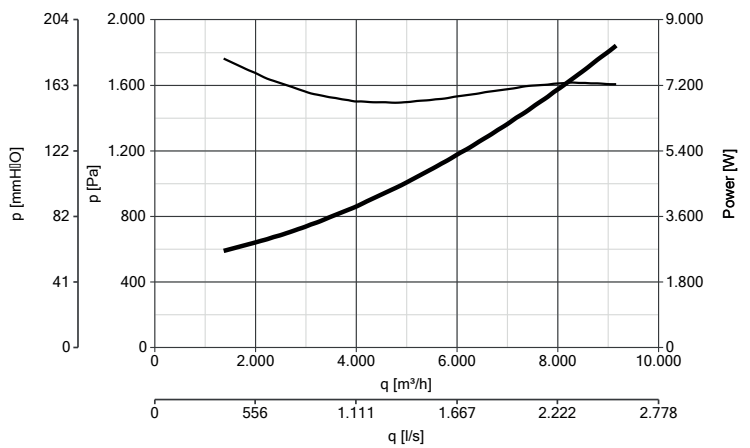

CMS 45/18 T4 11 kW
Code 30164

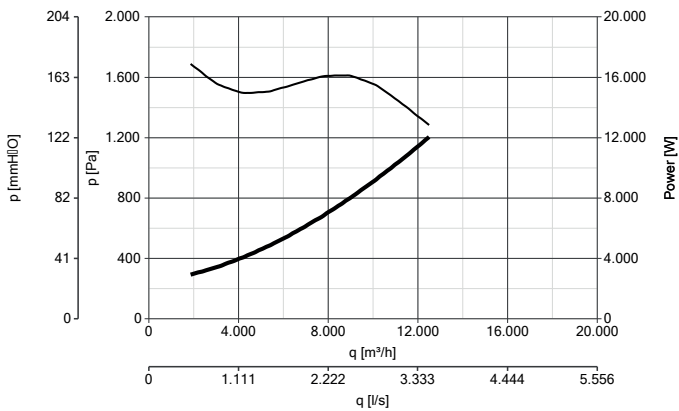

CMS 35/14 T6 1,1 kW
Code 30165

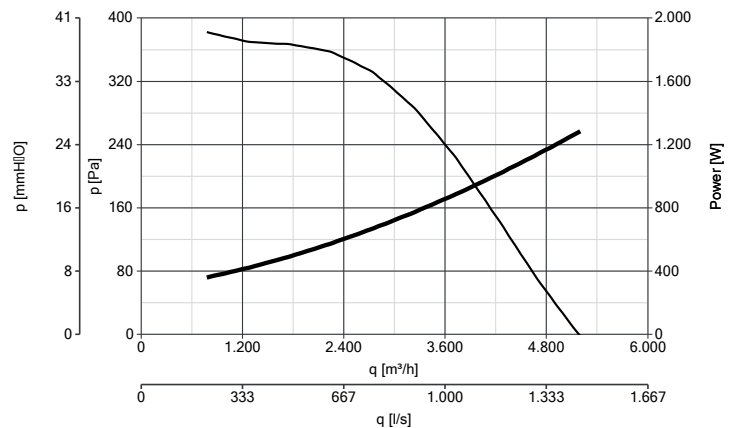



PERFORMANCE

CMS 40/16 T6 1,5 kW
Code 30166

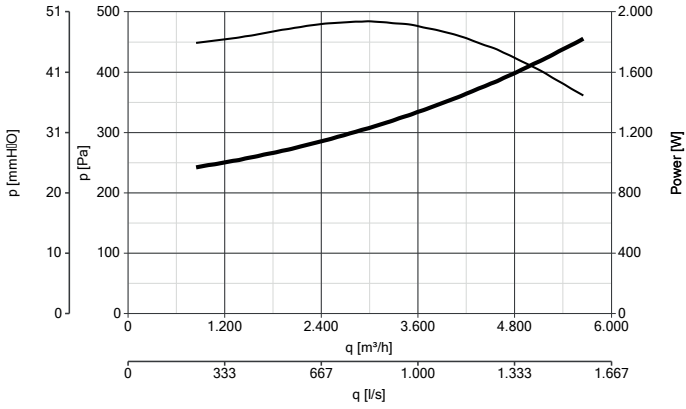

CMS 40/16 T6 2,2 kW
Code 30167

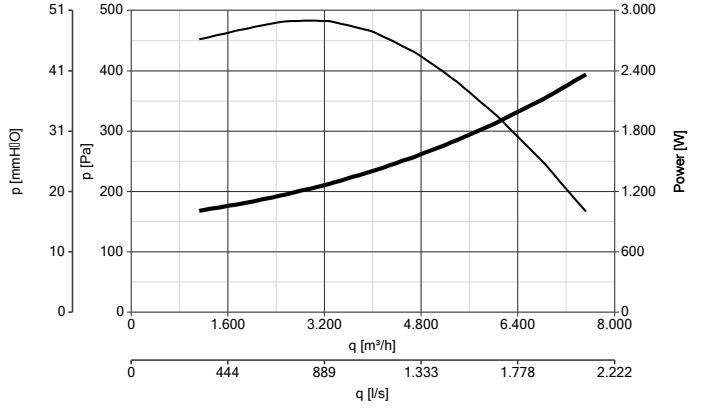

CMS 45/18 T6 2,2 kW
Code 30168

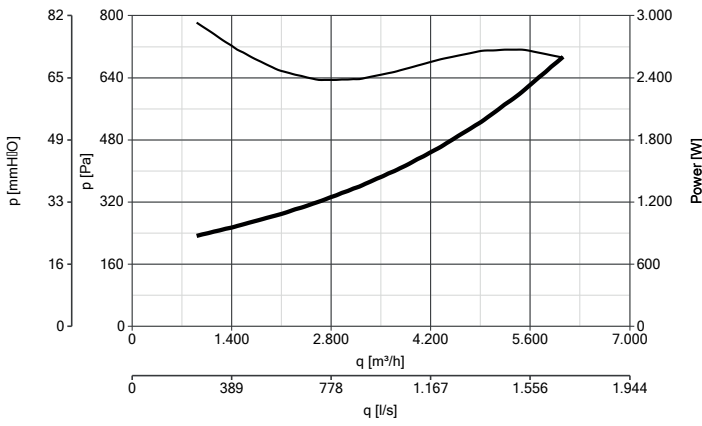

CMS 22/9 T2 1,5 kW
Code 30185

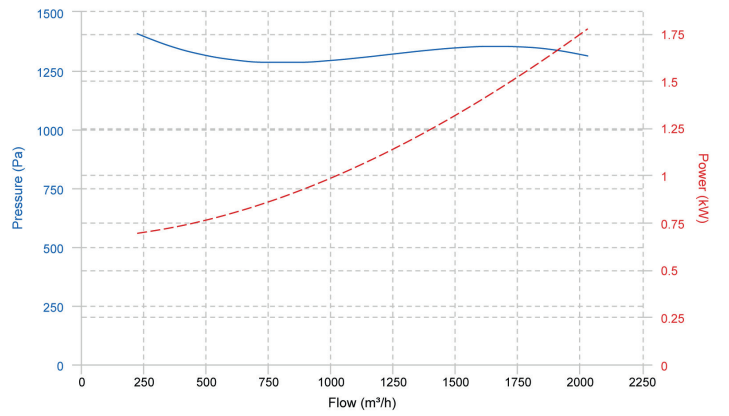

CMS 31/12 T2 3 kW P/R
Code 30186

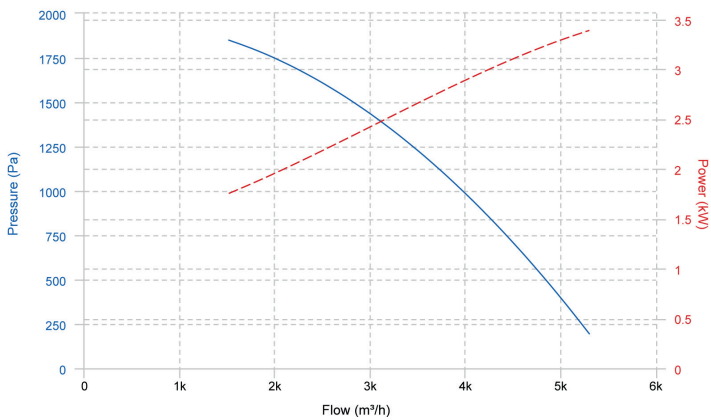

CMS 35/14 T2 5,5 kW P/R
Code 30187

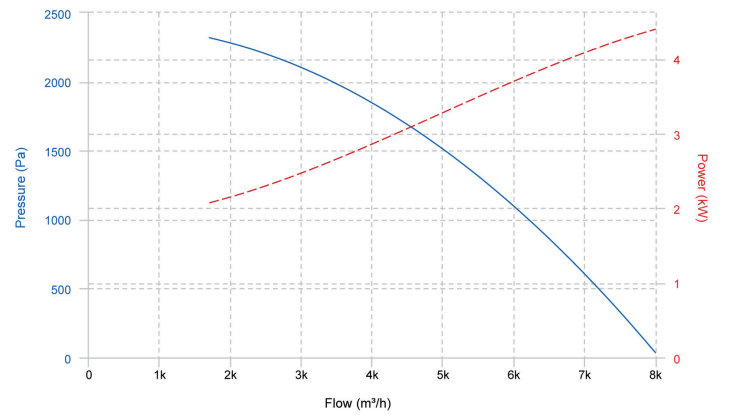

VORTICENT CMS
Medium-pressure industrial centrifugal fans

PERFORMANCE

CMS 40/16 T2 7,5 kW P/R
Code 30188

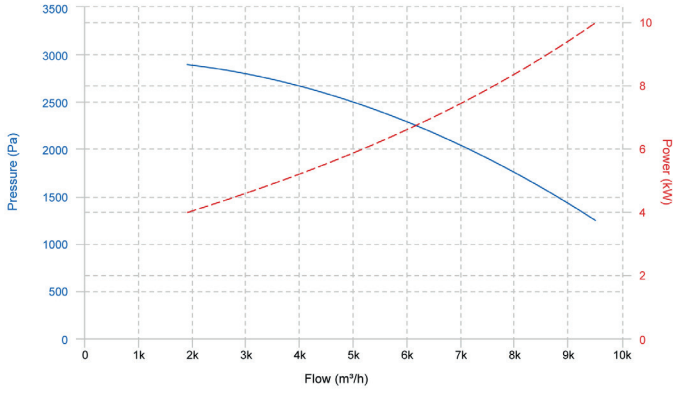

CMS 45/18 T2 11 kW P/R
Code 30189

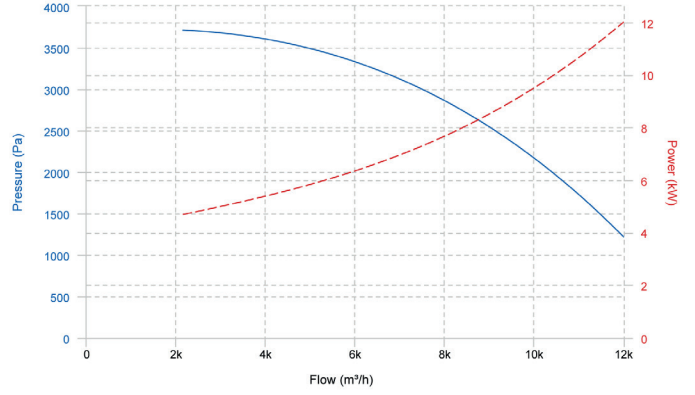

CMS 45/18 T2 15 kW P/R
Code 30190

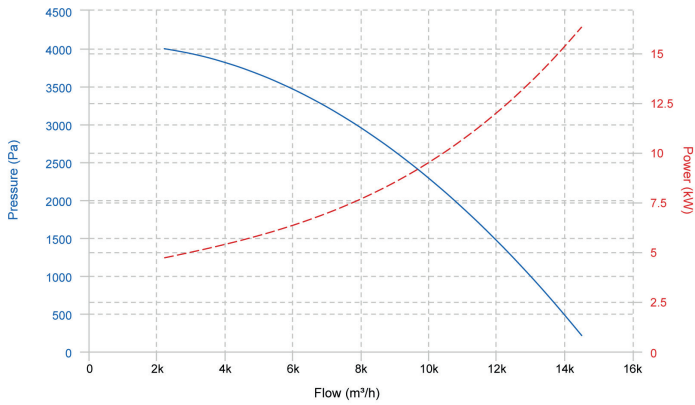

ACCESSORIES

ACCESSORIES	CODE	DESCRIPTION	MODELS	
SWT 25 3P	21673	"Start-stop" safety switch, compliant with the requirements of IEC 60947-1 and IEC 60947-3. Protection rating: IP65. Equipped with an auxiliary contact. Useful for cutting off the power supply before carrying out maintenance work on the fan.	All models	
MSRA 12/5	20239	Circular protective grille for fitting on the intake side. Designed to prevent direct contact between fingers and moving parts, made from galvanised steel or epoxy powder-coated steel, depending on the model.	30193 - 30147	
MSRA 14/5	20262		301314 - 30140 - 30142 30148	
MSRA 16/6	20263		30135 - 30141 - 30143 30149	
MSRA 18/7	20264		30136 - 30144	
MSRA 20/6-8	20265		30137 - 30138 - 30146	
MSRA 22/9	20240		30150 - 30151 - 30155 30185	
MSRA 25/10	20241		30152 - 30153 - 30156	
MSRA 28/11	20242		30154 - 30157	
MSRA 31/12	20243		30158	
MSRA 35/14	20244		30159 - 30160 - 30165	
MSRA 40/16	20245		30161 - 30162 - 30166 30167	
MSRA 45/18	20246		30136 - 30164 - 30168	
MSRBS 12/5	20247		Rectangular protective grille for fitting on the outlet side. Designed to prevent direct contact between fingers and moving parts, made from steel with an epoxy powder coating.	30139 - 30147
MSRBS 14/5	20248			30134 - 30140 - 30142 30148
MSRBS 16/6	20249			30135 - 30141 - 30143 30149
MSRBS 18/7	20250			30136 - 30144
MSRBS 20/6	20251			30137
MSRBS 20/8	20252	30138 - 30146		
MSRBS 22/9	20253	30150 - 30151 - 30155 30185		
MSRBS 25/10	20254	30152 - 30153 - 30156		
MSRBS 28/11	20255	30154		
MSRBS 31/12	20256	30158		
MSRBS 35/14	20257	30159 - 30160 - 30165		
MSRBS 40/16	20258	30161 - 30162 - 30166 30167		
MSRBS 45/18	20259	30163 - 30164 - 30168		

VORTICENT CMS
Medium-pressure industrial centrifugal fans

ACCESSORIES

ACCESSORIES	CODE	DESCRIPTION	MODELS
MFLAC 12/5	20228		30193 - 30147
MFLAC 14/5	20229		30134 - 30140 - 30142 30148
MFLAC 16/6	20230		30135 - 30141 - 30143 30149
MFLAC 18/7	20231		30136 - 30144
MFLAC 20/6-8	20232		30137 - 30138 - 30146
MFLAC 22/9	20233	Fitting flange for round pipes	30150 - 30151 - 30155 30185
MFLAC 25/10	20234		30152 - 30153 - 30156
MFLAC 28/11-31/12	20235		30154 - 30157 - 30158
MFLAC 35/14	20236		30159 - 30160 - 30165
MFLAC 40/16	20237		30161 - 30162 - 30166 30167
MFLAC 45/18	20238		30163 - 30164 - 30168
FLC1 - F400 10/12	21984		30139 - 30147
FLC1 - F400 15/16	21985		30134 - 30135 - 30140 - 30141 - 30142 - 30143 30148 - 30149
FLC1 - F400 20	21986		30136 - 30137 - 30138 30144 - 30146
FLC1 - F400 205	21987	Coupling flange made from flexible polyurethane reinforced with fibreglass fabric, designed to prevent vibrations. Approved in accordance with European standard EN 12101-3 (400°C/2h). Fire classification: M0. Supplied with 2 fixing clamps. Depth: 160 mm	30150 - 30151 - 30152 - 30153 - 30155 - 30156 30185
FLC1 - F400 30/31	21988		30154 - 30157 - 30158
FLC1 - F400 35	21989		30159 - 30160 - 30165
FLC1 - F400 40	21990		30161 - 30162 - 30166 30167
FLC1 - F400 45	21991		30163 - 30164 - 30168
FJ-F400	21669	Flexible joint between the fan and the duct	can be combined with all products in this range
CFB	20230	Front bracket (available on request)	30185
BOX-IC	20261	Soundproof cabinet available on request	

ACCESSORIES

ACCESSORIES	CODE	DESCRIPTION	MODELS
EI 12/5	20173		30139 - 30147
EI 14/5	20702	Connecting flange to be fitted to the outlet nozzle of the centrifugal fan	30140 - 30148
EI 16/6	20703		30141 - 30149
EI 22/9	20706		30185
EMC-T FTR 1.2-2.2A	21840		30142 - 30143 - 30144 - 30155 - 30156
EMC-T FTR 3.6A	21841		30142 - 30143 - 30146 - 30150 - 30155 - 30157 30165
EMC-T FTR 5-8A	21842	Single-phase and three-phase EMC filter, for use with variable-frequency speed controllers	30144 - 30146 - 30150 30151 - 30152 - 30153 30154 - 30156 - 30157 30158 - 30159 - 30165 30166 - 30167 - 30168
EMC-T FTR 12-16A	21842		30151 - 30152 - 30158 30160 - 30161 - 30162 30163
EMC-T FTR 23-29.5A	21844		30164
SWT 25 3P	21673	"Start-stop" safety switch	can be combined with all products in this range

REGULATORS

REGULATORS	CODE	DESCRIPTION	MODELS
IREM INVERTER 230 2.5A	12872		30142 - 30143 - 30147 30148 - 30149 - 30155
IREM INVERTER 230 4.2A	12873		30144 - 30146 - 30150 30156
IREM INVERTER 230 7A	12874		30157 - 30165 - 30166 30185
IREM INVERTER 230 10A	12875		30151 - 30152 - 30158
IRET INVERTER 400 1.2A	12876		30142 - 30143 - 30147 30148 - 30149 - 30155
IRET INVERTER 400 2.2A	12877	Single-phase or three-phase speed controller	30144 - 30156
IRET INVERTER 400 3.6A	12878		30146 - 30150 - 30157 30165 - 30185
IRET INVERTER 400 5A	12879		30151 - 30152 - 30158 30166
IRET INVERTER 400 8A	12880		30153 - 30154 - 30159 30167 - 30168 - 30186
IRET INVERTER 400 12A	12881		30160 - 30161 - 30187
IRET INVERTER 400 16A	12882		30162 - 30163 - 30188
IRET INVERTER 400 23A	12883		30164 - 30189
IRET INVERTER 400 29.5A	12884		30190

VORTICE GROUP COMPANIES

VORTICE S.P.A

Strada Cerca, 2
District of Zoate
20067 Tribiano
(Milan) Italy
Tel. (+39) 02 906991
vortice.com
V.A.T. IT 04474410968

BUSINESS UNIT INDUSTRIAL

Via B. Brugnoli 3,
37063 Isola della Scala
(Verona) Italy
Tel. (+39) 045 6631042
vorticeindustrial.com
V.A.T. IT 04474410968

VORTICE LIMITED

Beeches House
Eastern Avenue
Burton on Trent
DE13 0BB United Kingdom
Tel. (+44) (0) 1283-49.29.49
vortice.ltd.uk

CASALS VENTILACIÓN AIR INDUSTRIAL S.L.

Ctra. Camprodon, s/n 17860
Sant Joan de les Abadesses
(Girona) Spain
Tel. (+34) 972720150
casals.com

VORTICE LATAM S.A.

Bodega #6
Zona Franca Bes Alajuela,
Alajuela 20101
Costa Rica
Tel. (+506) 2201.6934
vortice-latam.com

VORTICE VENTILATION SYSTEM

(Changzhou) Co.LTD
No. 388 West Huanghe Road
Building 19, Changzhou
Post Code: 213000 China
Tel. (+86) 0519 88990150
vortice-china.com

VORTICE POLSKA

ul. Cybernetyki 19A,
02-677 Warszawa
Poland
biuropolska@vortice.com
vorticepolska.pl

The descriptions and illustrations in this catalogue are intended to be indicative and not binding. Without prejudice to the essential characteristics of the products described and illustrated here, VORTICE reserves the right to make, at any time and without notice, any changes to parts, aesthetic details or supply of accessories to its products that are deemed to be appropriate for improvement or for any construction or commercial requirement. This printout completely cancels and replaces all previous ones.

